

6. Winch

Servicing Your Winch

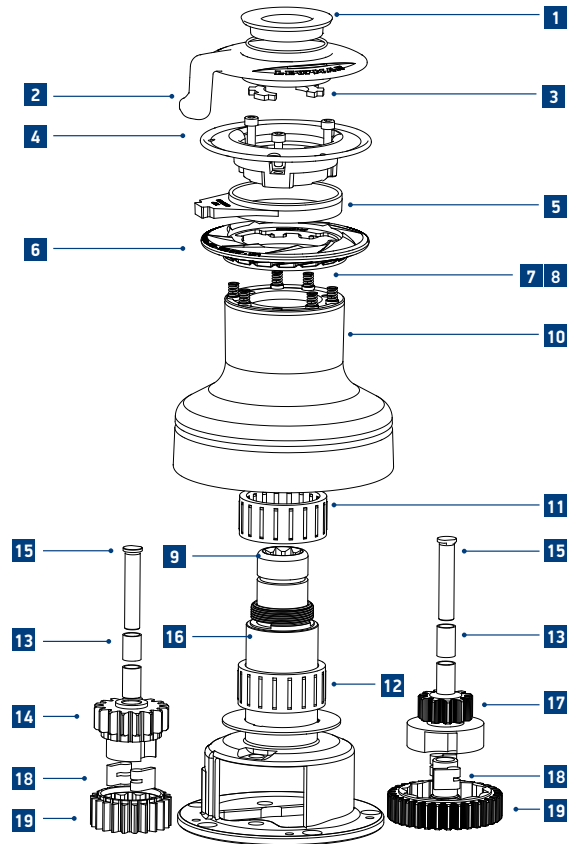

- | | |
|------------------|-----------------------------|
| 1. Top Cap | 10. Drum |
| 2. Feeder arm | 11. Roller bearing assembly |
| 3. Collet | 12. Drum washer |
| 4. Upper crown | 13. Gear spindle sleeve |
| 5. Stripper ring | 14. Pawl gear |
| 6. Lower crown | 15. Gear spindle |
| 7. Spring | 16. Centre stem |
| 8. Spring cup | 17. Pawl spring (not shown) |
| 9. Main spindle | 18. Pawl |
| | 19. Ratchet gear |



Frequency of servicing

Lewmar winches must be serviced regularly. Winches are required to carry deceptively high loads. Regular servicing, with attention to correct assembly and condition of parts, is vital to the safety and performance of your boat.

When?

1. Two or three times during active sailing season winches should be stripped, cleaned and re-lubricated.
2. At the end of each sailing season and before starting the new sailing season all Lewmar winches should be completely stripped, cleaned, thoroughly checked for damage and lubricated. (see the latest issue of the Lewmar Winch Service Manual available at www.lewmar.com)

External cleaning of the drum.

Chromed and stainless steel winches – wash drum regularly with fresh water and dry with a cloth. Non-abrasive liquid chrome cleaner can be used occasionally to remove dirt spots.

Alloy winches – wash drum regularly with fresh water and dry with a cloth. DO NOT use polishes or abrasives.

Servicing Winches

All components should be removed and cleaned in a paraffin bath during the course of servicing. If you do not have access to a paraffin bath, use half of an old plastic container with an old toothbrush. Even a cotton cloth soaked in paraffin or white spirit will suffice.

Caution

Some Lewmar winches contain plastic components which may be damaged by inappropriate cleaning agents. Always check the manufacturers directions before using any cleaning agents.

Greasing

Never use grease to lubricate your pawls, as this can lead to pawls sticking in their pockets and disabling the winch. Instead, lubricate with a light engine oil.

Use only a light smear of winch grease when lubricating ratchet tracks, gear teeth and bearings. Otherwise excess grease will be forced out and collect in potentially dangerous areas, such as pawl pockets.

Assembly

Winches must be re-assembled in the reverse sequence to the order of dismantling. After re-assembly, immediately check the winch functions correctly.

Mounting

Winches must be fitted as explained in the product manual (supplied with every winch and downloadable from www.lewmar.com).

Winches are self-draining and care should be taken to ensure the drain holes are not obstructed.

Ratchet Gears – Pawl Engagement

When assembling ratchet gears, check pawl engagement as shown below. Incorrect assembly will lead to back winding of the winch. This is very dangerous, so extreme care should be taken.



✘ Wrong



✔ Correct

Winch Maintenance Kits

Lewmar offers a full range of winch spares. Service kits include all common servicable spares including pawls, springs, sleeves, o-rings etc.

Full details of winch spares, including exploded diagrams to aid identification, are available from the spares section of www.lewmar.com



48000014

Suitable for

- Ocean Standard winch sizes 6-40
- Ocean ST winch sizes 14 & 16
- EVO ST winch size 15



48000019

Suitable for

- Ocean ST winch sizes 30-48
- EVO ST winch sizes 30-50



48000017

Suitable for

- Ocean ST winch sizes 50-65
- EVO ST winch sizes 55-65



48000018

Suitable for

- Ocean ST winch size 68
- EVO ST winch size 70



19701500

Winch Maintenance Pack



19701000

Grease — 100g



19701100

Grease - 300g



19701600

Race Lube -55ml

Winch Spares Kits

A full range of spares kits are also available, from bearing packages to jaw kits and everything in between. Contact your local Lewmar supplier or visit the spares section of www.lewmar.com

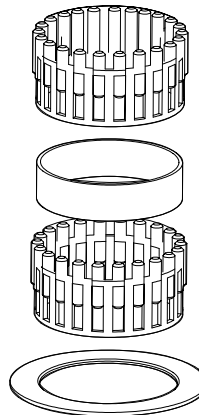

Drum Bearing Kit

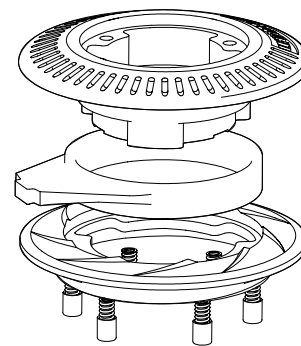

Jaw Kit

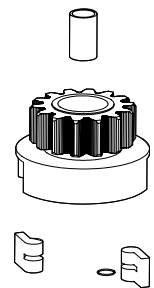

Pawl Gear Kit