



Coastline Technology Windlass Radio Remote Control



Installation and Operating Manual

Coastline Technology Ltd.
17 Old Lane, Low Mill Village, Addingham, W. Yorks, LS29 0SA, UK
Tel: +44 07887 558988
Email: info@coastlinetechnology.com
Web: www.coastlinetechnology.com

Compliance

FCC Statement

This device complies with Part 15 of the FCC Rules. Operation is subject to the following two conditions:

- (1) This device may not cause harmful interference
- (2) This device must accept any interference received, including interference that may cause undesired operation.

Any changes or modification not expressly approved by the party responsible for compliance could void the user's ability to operate the equipment.

This equipment complies with FCC radiation exposure limits set forth for an uncontrolled environment. This equipment should be installed and operated with a minimum distance of 20cm between the radiator and your body. This transmitter must not be co-located or operating in conjunction with any other antenna or transmitter.



Contains FCC ID: W7OMRF24J40MDME



0890

IEEE 802.11 b/g/n 2.4GHz WiFi (International)

EU Directive 1999/5/EC (R&TTE Directive)

EN 300 328 V1.7.1 (2006-10)

Contents

Compliance

Remote

- Operation
- Safety
- Special functions
- Batteries
- Low battery indication
- Battery replacement

Receiver

- Operation
- Power connections Internal fuse

Location and Mounting Wiring Diagrams

- Simple Installation
- Dual Control Installation

Specification

Receiver Mounting Template

Coastline Technology Ltd.
17 Old Lane
Low Mill Village Addingham
W.Yorks LS29 0SA UK
Tel: 07887 558988
Email info@coastlinetechnology.com
www coastlinetechnology.com

Serial No.	
Frequency	2.4GHz ISM GSKF (International)
Date	

Remote

Operation

To switch on the Remote press and hold down both buttons for 2 seconds. The green led will light up indicating that the remote is now 'awake'.

Release both buttons and the green led will go out and the Remote is ready for use.

The Remote switches itself off after 10 minutes of inactivity.

The 2 second 'switch on' routine is a deliberate safety measure to prevent unintentional operation of the windlass

In normal operation the green led is on continuously while a button is pressed. If the green led flickers this indicates poor communication with the Receiver.

SAFETY

Great care should be taken with the windlass operation to ensure that anyone on the foredeck is well clear of the anchor chain and windlass mechanism when the windlass is operated.

Anyone using the Remote away from the foredeck must ensure that all foredeck crew are safe.

Special Functions

For normal operation no additional commands are required to operate the system, however spare Remotes can be added to the system and these are programmed with the same Receiver ID code. See 'Special Functions' towards the end of this manual.

Batteries

The Remote uses 3 x AAA 1.5v Lithium Iron batteries (Energizer Ultimate Lithium). These are non-rechargeable. We strongly recommend that only this battery type be used, as they do not leak. They have a shelf life in excess of 20 years and operate from -40°C to 60°C.

The supplied batteries have sufficient capacity to allow for 5 minutes of windlass operation every day for 2 years. As such, most recreational users are unlikely to ever need to replace the batteries.

Low Battery Indication

If the batteries are getting low the red led in the Battery Indicator window will come on. The Remote will continue to function for a considerable period but the batteries should be replaced as soon as is convenient.

Battery Replacement

To replace the batteries, remove the back panel (2 screws) and carefully lever them out. The battery connections are very firm and we recommend inserting the negative (non-dimple) end first and then pushing the battery towards the negative end and then down. Do NOT bend back the battery connection arms or they may be permanently damaged.

Receiver

Operation

Each Receiver has a unique ID code that is factory programmed. Additional Remotes can be supplied, however only one Remote should be used at a time.

The Receiver can be connected to work in parallel with foot switches, cockpit controls or cabled remotes.

The Receiver detects if the windlass is already under external control to avoid conflict situations.

Power Connections

The Receiver is powered from the boat's battery, and versions are available for 12v and 24v operation.

The positive connection should be taken to the fused side of the windlass supply (see wiring diagrams).

Black - connect to the boat's 0v supply

Red - connect to the boat's +12v or +24v supply

Yellow - outputs +12v or +24v when the 'Up' button is pressed

Blue - outputs +12v or +24v when the 'Down' button is pressed

Internal Fuse

The receiver is fused internally with a 10amp 20mm anti-surge fuse.

**Note

Although highly rated, the relay switches inside the Receiver have a 10amp maximum capacity and should not be directly connected to the windlass itself.

Location and Mounting

The Receiver can be mounted anywhere on the boat. Normally it is convenient to mount it in the chain locker where it is close to the windlass and windlass control box (solenoid).

The Receiver should be mounted with the cable gland pointing downwards. Ideally mount the receiver above the waterline and as high as possible.



The mounting holes for the Receiver enclosure can be accessed by opening the lid.

To open the Receiver lid insert a small (3.5mm) flat bladed screwdriver in the slot as shown and pivot the screwdriver to the right.

A Receiver Mounting Template is provided.

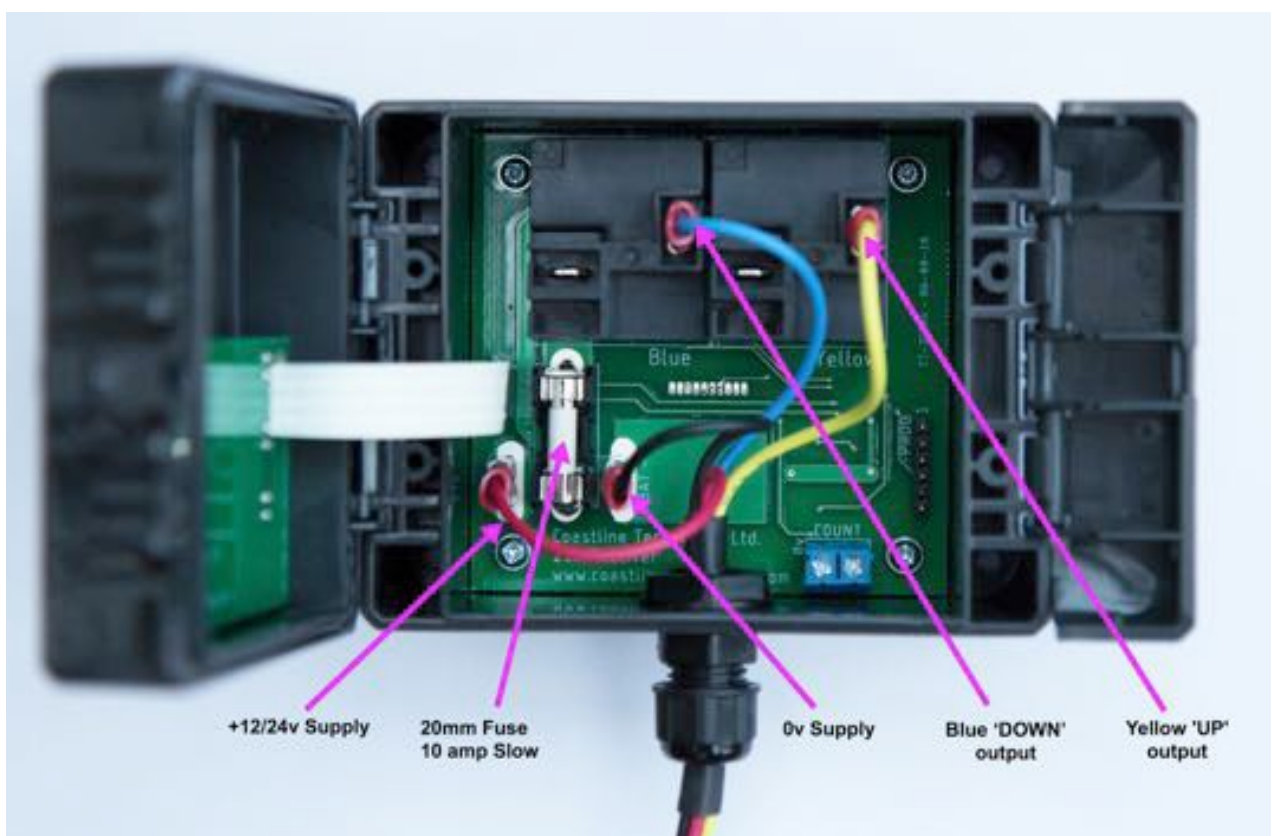

Installation

Simple Installation

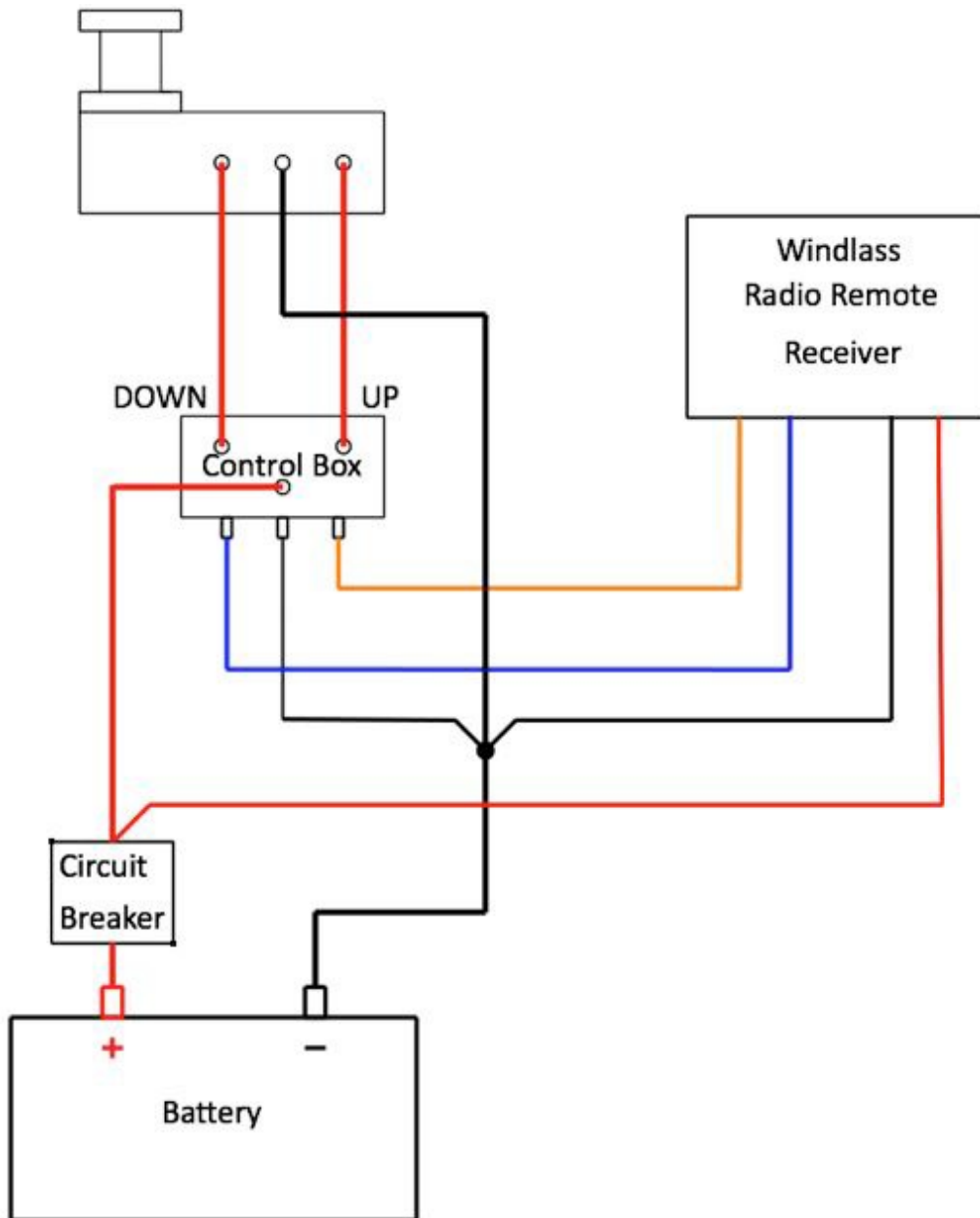

A high current supply from the boat's battery goes to a Circuit Breaker (typ. 180 amp), and then on to the centre power connection on the Control Box.

The power supply connections for the Receiver are connected to the 0v (black) and +12v/+24v (red).

The yellow 'Up' and blue 'Down' wires from the receiver connect to the control inputs of the Control Box.

Dual Control Installation

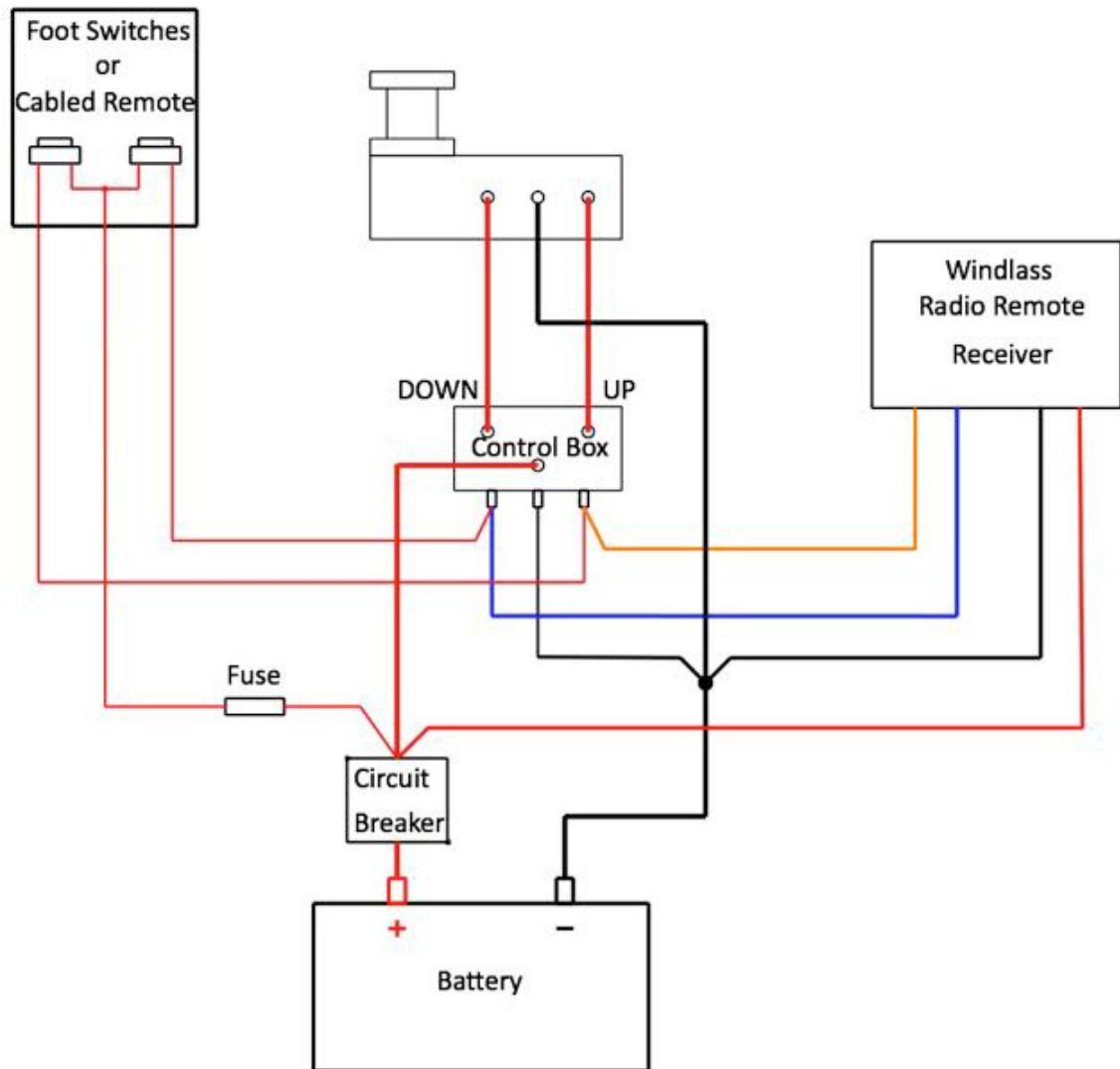

The Windlass Radio Remote can be wired in parallel with a cabled remote or foot switches.

The Receiver senses if the cabled remote / foot switches are being used to avoid conflict situations.

The above wiring diagrams show typical installations and will be applicable in the great majority of installations.

***Please contact Coastline Technology if you have any queries regarding a particular installation.

Special Functions

Programming a Spare Remote

Spare Remotes can be ordered and are factory programmed with the ID of the Receiver. If a Remote has not been preprogrammed it can be programmed in-situ on the boat.

The Remote must be in 'sleep' mode i.e. after 10 mins of inactivity.

Switch off power to the Receiver for 5 seconds and then switch it on again. You now have 1 minute in which to program the Remote.

Press and hold both buttons on the Remote for 20 seconds (30 secs max).

After 2 seconds the green led will light up, after 20 seconds the green led will go off and the red led will go on.

Release both buttons. The Remote is now in Program Mode.

The red led will go off once the Remote has been programmed with the Receiver's ID.

The 'UP' and 'DOWN' leds on the Receiver will both go on briefly before going off and the Remote will then go into 'sleep' mode.

Reverting to Factory programmed ID

If for any reason it is necessary to revert to the original factory programmed ID then the following procedure should be followed:

Remote must be in 'sleep' mode i.e. after 10 mins of inactivity.

Press and hold both buttons on the Remote for 40 seconds (60 secs max).

After 2 seconds the green led will light up, after 20 seconds the green led will go off and the red led will go on. After 40 seconds the red led will go off.

The green and red leds will then blink alternately.

Release both buttons and the remote will then go into 'sleep' mode.

Forced 'Sleep' mode

The Remote can be forced to go to 'sleep' (as alternative to 10 mins of inactivity).

Press and hold both buttons for 60 seconds. After 60 seconds both red and green leds will come on.

Release both buttons and the Remote will enter 'sleep' mode.

Specification

Transmitter

Weight	120g
Enclosure	ABS, waterproof (IP 65)
Batteries	3 x AAA Lithium Iron (we recommend Energiser Ultimate Lithium)
Current	0.1uA (sleeping), 5mA (standby), 20mA (active)
Frequency	2.4GHz ISM GFSK (International)
RF Power	20 dBm
Temp	-20°C to 54°C

Receiver

Size	110 x 80 x 65mm Weight 250 g (excluding cables)
Enclosure	ABS, waterproof (IP 54)
Supply	+12v (15v max) or +24v (30v max)
Current	30mA (standby), 120mA (active)
Frequency	2.4GHz ISM GFSK (International)
RF Power	20 dB
Temp	-20°C to 54°C

Compliance



Contains FCC ID: W70MRF24J40MDME

IEEE 802.11 b/g/n 2.4GHz WiFi (International)

EU Directive 1999/5/EC (R&TTE Directive)

EN 300 328 V1.7.1 (2006-10)



Radio Remote Receiver - Mounting Template

