



406-S

609-S

811-S

JIB REEFING - OWNER'S MANUAL

GB

ENROULEUR DE FOC - NOTICE D'UTILISATION

F

ROLLREFFANLAGE - AUFBLASBARE RETTUNGSWESTEN

D

ROLREEFSYSTEEM - GEBRUIKERSHANDLEIDING

NL

ENROLLADOR - GUIA DE UTILIZACION

E

RULLFOCKSYSTEM - INSTRUKTIONER OCH HANDHAVANDE

S

AVVOLGITORE - MANUALE D'USO

I

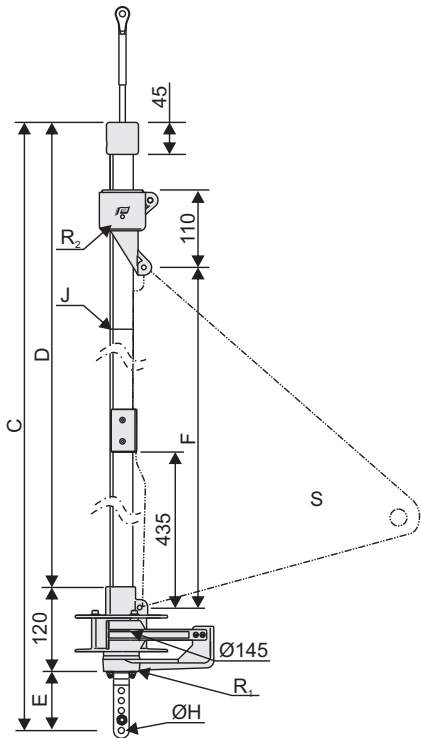
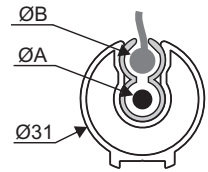

406-S

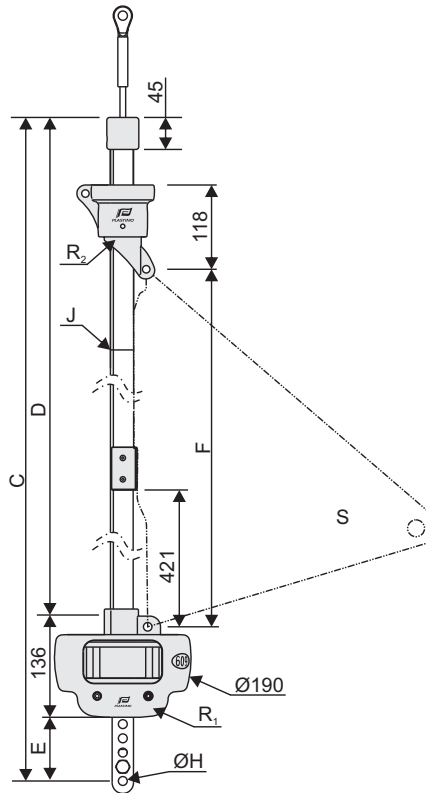

609-S

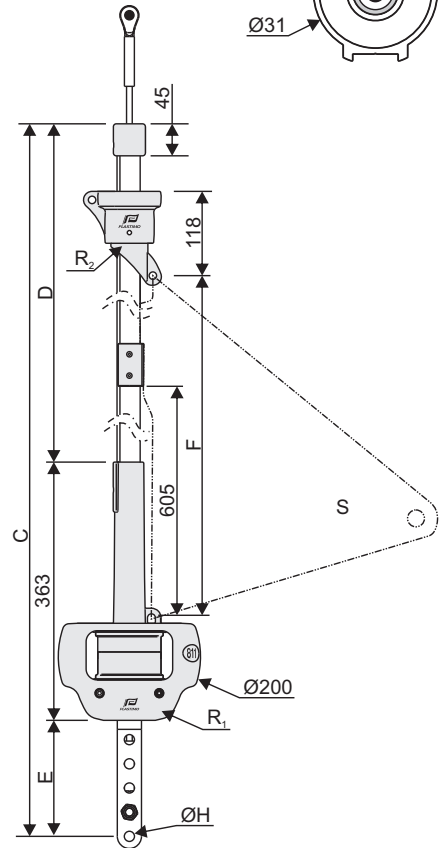

811-S

	GB		F		D		NL		E		S		I		
	chainplate	turnbuckle	latte	ridoir	Terminal- montage	Stagspanner- montage	steyenplaa- tuitvoering	spanschroev- luitvoering	placas	tensor			Landre	Arriadato	
406-S	25722	25723	25722	25723	25722	25723	25722	25723	25722	25723	25723	25722	25723	25723	
609-S	58202	58203	58202	58203	58202	58203	58202	58203	58202	58203	58203	58202	58203	58203	
811-S	58204		58204		58204		58204		58204		58204	58204		58204	
ØA	forestay : Ø4-7mm		étai : Ø4-7mm		Vorstag : Ø4-7mm		voorstag : Ø4-7mm		estay : Ø4-7mm		Förstags : Ø4-7mm		Strallo : Ø4-7mm		
ØB	luffrope : Ø6.5mm		ralingue : Ø6.5mm		Vorliek : Ø6.5mm		voorlijk : Ø6.5mm		relinga : Ø6.5mm		Lik : Ø6.5mm		ralinga : Ø6.5mm		
C	407-S	6.20m	6.28m	6.20m	6.28m	6.20m	6.28m	6.20m	6.28m	6.20m	6.28m	6.28m	6.20m	6.28m	
	609-S	9.22m	9.40m	9.22m	9.40m	9.22m	9.40m	9.22m	9.40m	9.22m	9.40m	9.40m	9.22m	9.40m	
	811-S	11.05m		11.05m		11.05m		11.05m		11.05m		11.05m	11.05m		
D	407-S	5.95m		5.95m		5.95m		5.95m		5.95m		5.95m	5.95m		
	609-S	8.94m		8.94m		8.94m		8.94m		8.94m		8.94m	8.94m		
	811-S	10.44m		10.44m		10.44m		10.44m		10.44m		10.44m	10.44m		
E	407-S	65mm	150mm	65mm	150mm	65mm	150mm	65mm	150mm	65mm	150mm	150mm	65mm	150mm	
	609-S	115mm	285mm	115mm	285mm	115mm	285mm	115mm	285mm	115mm	285mm	285mm	115mm	285mm	
	811-S	220mm		220mm		220mm		220mm		220mm		220mm	220mm		
F	407-S	5.82m		5.82m		5.82m		5.82m		5.82m		5.82m	5.82m		
	609-S	8.80m		8.80m		8.80m		8.80m		8.80m		8.80m	8.80m		
	811-S	10.49m		10.49m		10.49m		10.49m		10.49m		10.49m	10.49m		
G	407-S														
	609-S	I groove		I gorge		I Nuten		I zeilgroeven		I relingas		I likrännor		I gole	
	811-S														
ØH	407-S	8.5mm		8.5mm		8.5mm		8.5mm		8.5mm		8.5mm	8.5mm		
	609-S	12.5mm		12.5mm		12.5mm		12.5mm		12.5mm		12.5mm	12.5mm		
	811-S	14.3mm		14.3mm		14.3mm		14.3mm		14.3mm		14.3mm	14.3mm		
J	407-S														
	609-S	coupling units : aluminium+screws		jonctions aluminium + vis		Verbindungen Alu- minium +Schrauben		koppelstuk alu + schroeven		Empalmes aluminio + tornillos		Kopplingar alumi- nium + skruv		Giunzione aluminio + vite	
	811-S														
R1	407-S	bearing: Delrin		roulement Delrin		Kugellager Delrin		lagering Delrin		Rodamientos Delrin		Kullager Delrin		cuscinetti Delrin	
	609-S	bearing: Delrin,inox		roulement Delrin,inox		Kugellager Delrin,inox		lagering Delrin,RVS		Rod. Delrin,inox		Kulla. Delrin,rostfritt		cuscinetti Delrin,inox	
	811-S	bearing: Delrin, Torlon		roulement Delrin, Torlon		Kugellager Delrin, Torlon		lagering Delrin, Torlon		Rod. Delrin, Torlon		Kulla. Delrin, Torlon		cusi. Delrin, Torlon	
R2	407-S	bearing: Delrin		roulement Delrin		Kugellager Delrin		lagering Delrin		Rodamientos Delrin		Kullager Delrin		cuscinetti Delrin	
	609-S	bearing: Delrin, Torlon		roulement Delrin, Torlon		Kugellager Delrin, Torlon		lagering Delrin, Torlon		Rodamientos Delrin, Torlon		Kullager Delrin, Torlon		cuscinetti Delrin, Torlon	
	811-S	bearing: Delrin, Torlon		roulement Delrin, Torlon		Kugellager Delrin, Torlon		lagering Delrin, Torlon		Rodamientos Delrin, Torlon		Kullager Delrin, Torlon		cuscinetti Delrin, Torlon	
S	407-S	12m ²		12m ²		12m ²		12m ²		12m ²		12m ²	12m ²		
	609-S	25m ²		25m ²		25m ²		25m ²		25m ²		25m ²	25m ²		
	811-S	35m ²		35m ²		35m ²		35m ²		35m ²		35m ²	35m ²		

406-S

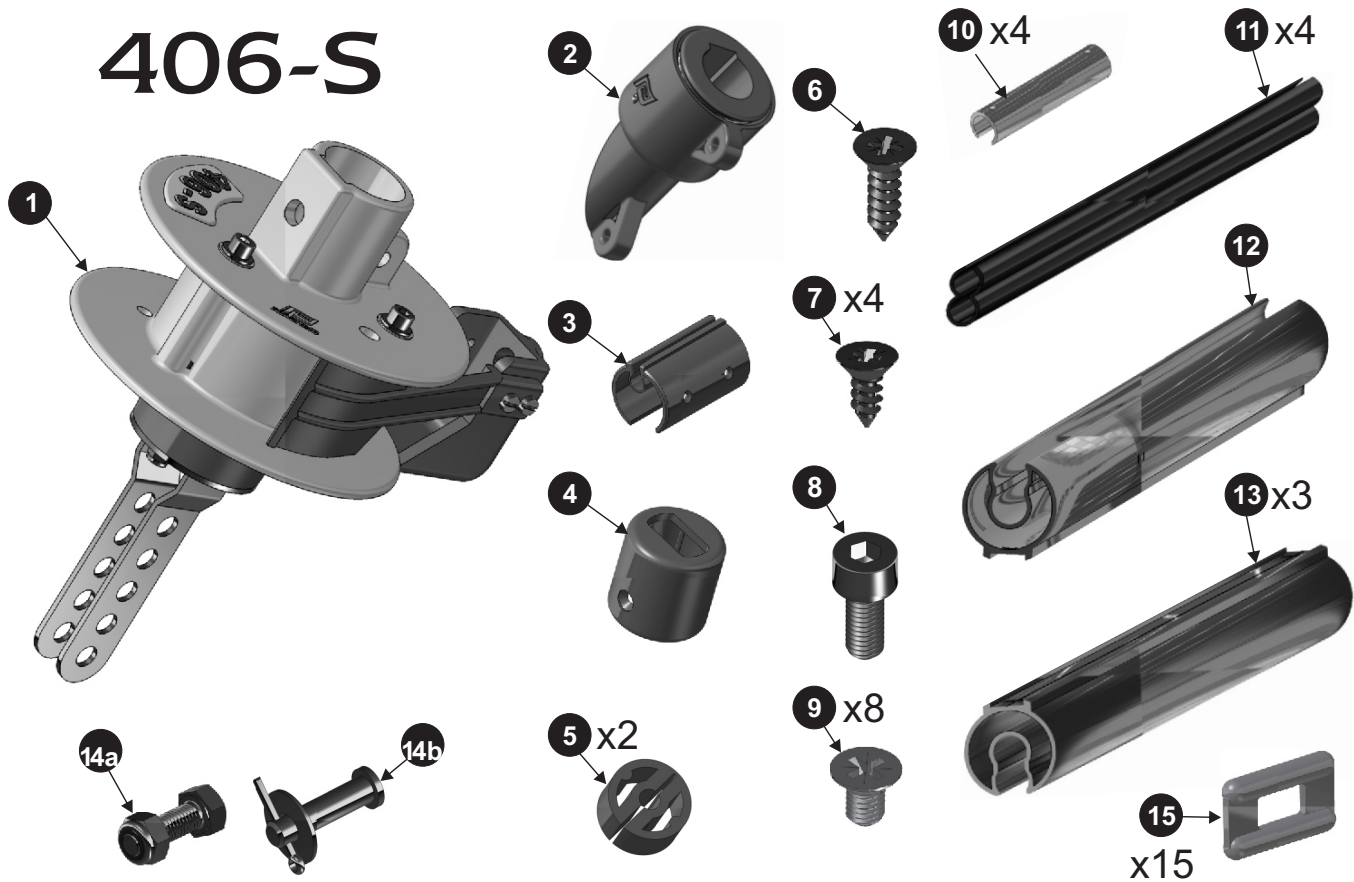

	GB	F	D	NL	E	S	I
1	1 drum unit	1 ensemble tambour	1 Trommel	1 roltrommel	1 conjunto tambor	1 Trumma med revlinematare	1 insieme tamburo
2	1 halyard swivel	1 émerillon	1 Fallwirbel	1 valwartel	1 giratorio	1 Fallsvirvel	1 mulinello
3	1 boltrope prefeeder	1 guide ralingue	1 Liekeinführung	1 voorlijkinvoer	1 guía relinga	1 Segelinmatare	1 guida ralinga
4	1 top end stop	1 embout profil	1 Profilansatzstück	1 top eind stuk	1 terminal tope	1 Toppdel	1 Terminale profilato
5	2 bearings	2 paliers de profil	2 Stopper	2 lagers	2 cojinetes	2 Lagringar	2 Supporti
6	4 screws Ø3.9x9.5 (prefeeder)	4 vis tôle TF Ø3.9x9.5 fixation guide ralingue	4 Schraube Ø3.9x9.5 (Liekeinführung)	4 schroeven Ø3.9x9.5 (voorlijkinvoer)	4 tornillos Ø3.9x9.5 (guía relinga)	4 spårskruv Ø3.9x9.5 (Segelinmatare)	4 viti lamiera Ø3.9x9.5 (guida ralinga)
7	1 screw Ø4.8x12. (top end stop)	1 vis tôle TF Ø4.8x12. fixation embout profil	1 Schraube Ø4.8x12. (Profilansatzstück)	1 schroef Ø4.8x12. (top eind stuk)	1 tornillo Ø4.8x12. (terminal tope)	1 spårskruv Ø4.8x12. (Toppdel)	1 vite lamiera Ø4.8x12 (terminale profilato)
8	1 screw M5x12 (base spar)	1 vis Chc M5x12 fixation profil bas	1 Schraube M5x12 (unteres Profil)	1 schroef M5x12 (basisprofiel)	1 tornillo M5x12 (perfil bajo)	1 insex M5x12 (Bottenprofil)	1 vite a brugola M5x12 (profilato basso)
9	8 screws M5x8 (spar connections)	8 vis TF M5x8 liaison profils	8 Schraube M5x8 (Verbindung der Profile)	8 bouten M5x8 (koppelstukken)	8 Tornillos M5x8 (unión perfiles)	8 insex M5x8 (profielkopplingarna)	8 vite M5x8 (collegamento profilati)
10	4 Coupling sleeves	4 pièces de jonction aluminium	4 Verbindungsstücke	4 koppelstukken	4 piezas de uniones	4 Skarvstycken	4 Pezzi di giunzione
11	4 PVC liners	4 profils PVC	4 PVC-Profile	4 PVC binnenprofielen	4 Perfiles PVC	4 Innerprofil i PVC - plastprofil	4 Profilati PVC
12	1 base spar	1 profil aluminium bas	1 unteres Profil	1 basisprofiel	1 perfil bajo	1 Bottenprofil	1 profilato basso
13	3 Intermediate spars	3 profils aluminium intermédiaires	3 Zwischenprofile	3 standaardprofielen	3 Perfiles intermedios	3 Standard profiler	3 Profilati intermedi
14a	1 screw + nut M8x35 => chainplate	1 vis + écrou M8x35 modèle lattes	1 Schraube M8x35 Terminalmontage	1 bunt M8x35 stevenplaatuitvoering	1 tornillo M8x35 (placas)	1 insex M8x35	1 Vite M8x35 Modello Landre
14b	1 Shouldered clevis pin Ø8 (=> turnbuckle)	1 axe épaulé Ø8 modèle ridoir	1 Bolzen, dick Ø8 Stagspannermontage	1 pen Ø8 spanschroefuitvoering	1 Bulón Ø8 (tensor)	1 Riggbult Ø8	1 Asse a testa Ø8 Modello arridatoi
15	15 PVC slide (=> turnbuckle)	15 coulisseau plastique modèle ridoir	15 PVC Rutscher Stagspannermontage	15 PVC-leuver spanschroefuitvoering	15 patin (tensor)	15 Plasttravare	15 guida in plastica Modello arridatoi

609-S

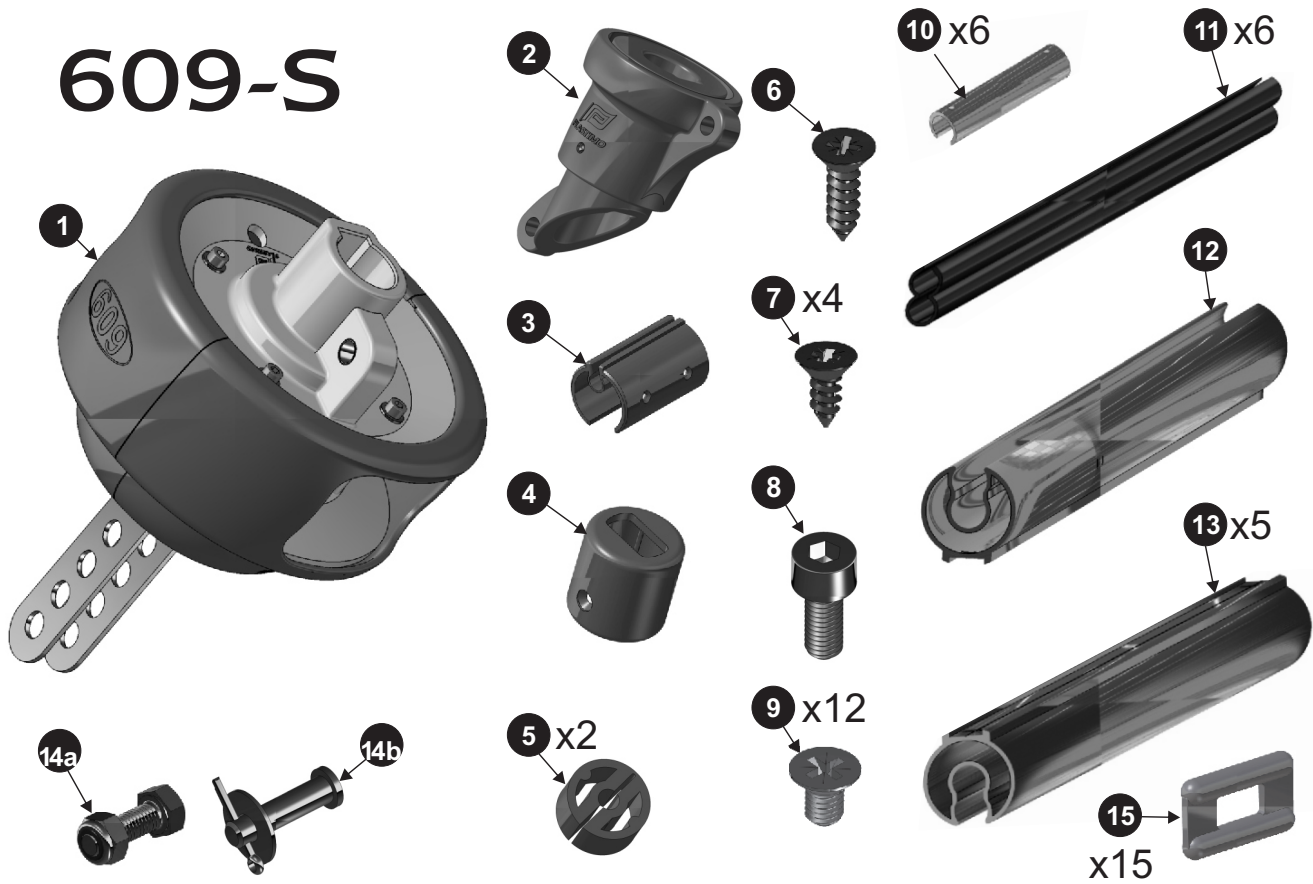

	GB	F	D	NL	E	S	I
1	1 drum unit	1 ensemble tambour	1 Trommel	1 roltrommel	1 conjunto tambor	1 Trumma	1 insieme tamburo
2	1 halyard swivel	1 émerillon	1 Fallwirbel	1 valwartel	1 giratorio	1 Fallsvirvel	1 mulinello
3	1 boltrope prefeeder	1 guide ralingue	1 Liekeinführung	1 voorlijkinvoer	1 guía relinga	1 Segelinmatare	1 guida ralinga
4	1 top end stop	1 embout profil	1 Profilansatzstück	1 top eind stuk	1 terminal tope	1 Toppdel	1 Terminale profilato
5	2 bearings	2 paliers de profil	2 Stopper	2 lagers	2 cojinetes	2 Lagringar	2 Supporti
6	4 screws Ø3.9x9.5 (prefeeder)	4 vis tôle TF Ø3.9x9.5 fixation guide ralingue	4 Schraube Ø3.9x9.5 (Liekeinführung)	4 schroeven Ø3.9x9.5 (voorlijkinvoer)	4 tornillos Ø3.9x9.5 (guía relinga)	4 spårskruv Ø3.9x9.5 (Segelinmatare)	4 viti lamiera Ø3.9x9.5 (guida ralinga)
7	1 screw Ø4.8x12. (top end stop)	1 vis tôle TF Ø4.8x12. fixation embout profil	1 Schraube Ø4.8x12. (Profilansatzstück)	1 schroef Ø4.8x12. (top eind stuk)	1 tornillo Ø4.8x12. (terminal tope)	1 spårskruv Ø4.8x12. (Toppdel)	1 vite lamiera Ø4.8x12 (terminale profilato)
8	1 screw M5x12 (base spar)	1 vis Chc M5x12 fixation profil bas	1 Schraube M5x12 (unteres Profil)	1 schroef M5x12 (basisprofiel)	1 tornillo M5x12 (perfil bajo)	1 insex M5x12 (Bottenprofil)	1 vite a brugola M5x12 (profilato basso)
9	12 screws M5x8 (spar connections)	12 vis TF M5x8 liaison profils	12 Schraube M5x8 (Verbindung der Profile)	12 bouten M5x8 (koppelstukken)	12 Tornillos M5x8 (unión perfiles)	12 insex M5x8 (profilkopplingarna)	12 vite M5x8 (collegamento profilati)
10	6 Coupling sleeves	6 pièces de jonction aluminium	6 Verbindungsstücke	6 koppelstukken	6 piezas de uniones	6 Skarvstycken	6 Pezzi di giunzione
11	6 PVC liners	6 profils PVC	6 PVC-Profile	6 PVC binnenprofielen	6 Perfiles PVC	6 Innerprofil i PVC - plastprofil	6 Profilati PVC
12	1 base spar	1 profil aluminium bas	1 unteres Profil	1 basisprofiel	1 perfil bajo	1 Bottenprofil	1 profilato basso
13	5 Intermediate spars	5 profils aluminium intermédiaires	5 Zwischenprofile	5 standaardprofielen	5 Perfiles intermedios	5 Standard profiler	5 Profilati intermedi
14a	1 screw+nut M12x35 => chainplate	1 vis+écrou M12x35 modèle lattes	1 Schraube M12x35 Terminalmontage	1 bunt M12x35 stevenplaatuitvoering	1 tornillo M12x35 (placas)	1 insex M12x35	1 Vite M12x35 Modello Landre
14b	1 Shouldered clevis pin Ø12 (=> turnbuckle)	1 axe épaulé Ø12 modèle ridoir	1 Bolzen, dick Ø12 Stagspannermontage	1 pen Ø12 spanschroefuitvoering	1 Bulón Ø12 (tensor)	1 Riggbult Ø12	1 Asse a testa Ø12 Modello arridatoi
15	15 PVC slide (=> turnbuckle)	15 coulisseau plastique modèle ridoir	15 PVC Rutscher Stagspannermontage	15 PVC-leuver spanschroefuitvoering	15 patin (tensor)	15 Plasttravare	15 guida in plastica Modello arridatoi

811-S

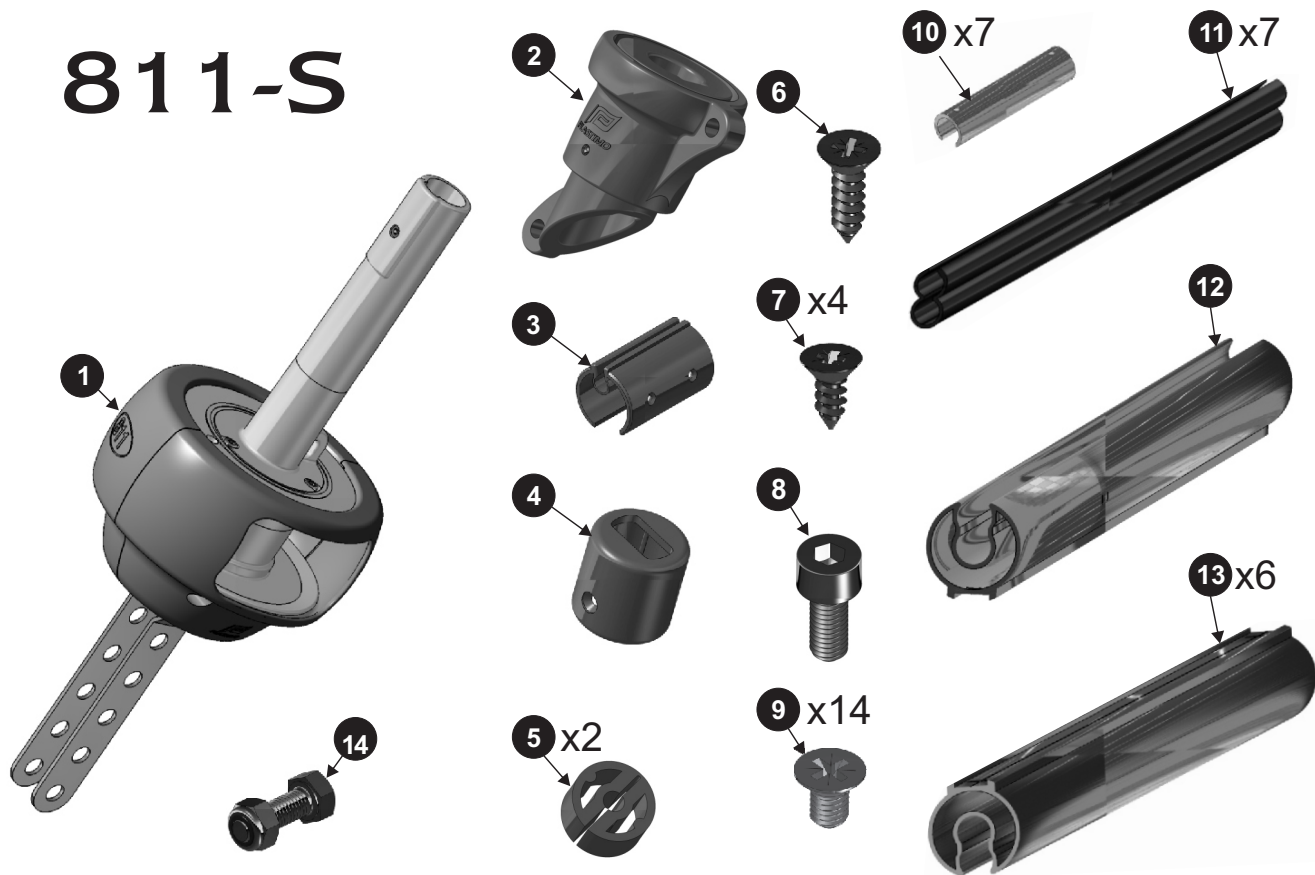

	GB	F	D	NL	E	S	I
1	1 drum unit	1 ensemble tambour	1 Trommel	1 roltrommel	1 conjunto tambor	1 Trumma	1 insieme tamburo
2	1 halyard swivel	1 émerillon	1 Fallwirbel	1 valwartel	1 giratorio	1 Fallsvirvel	1 mulinello
3	1 boltrope prefeeder	1 guide ralingue	1 Liekeinführung	1 voorlijkinvoer	1 guía relinga	1 Segelinmatare	1 guida ralinga
4	1 top end stop	1 embout profil	1 Profilansatzstück	1 top eind stuk	1 terminal tope	1 Toppdel	1 Terminale profilato
5	2 bearings	2 paliers de profil	2 Stopper	2 lagers	2 cojinetes	2 Lagringar	2 Supporti
6	4 screws Ø3.9x9.5 (prefeeder)	4 vis tôle TF Ø3.9x9.5 fixation guide ralingue	4 Schraube Ø3.9x9.5 (Liekeinführung)	4 schroeven Ø3.9x9.5 (voorlijkinvoer)	4 tornillos Ø3.9x9.5 (guía relinga)	4 spårskruv Ø3.9x9.5 (Segelinmatare)	4 viti lamiera Ø3.9x9.5 (guida ralinga)
7	1 screw Ø4.8x12. (top end stop)	1 vis tôle TF Ø4.8x12. fixation embout profil	1 Schraube Ø4.8x12. (Profilansatzstück)	1 schroef Ø4.8x12. (top eind stuk)	1 tornillo Ø4.8x12. (terminal tope)	1 spårskruv Ø4.8x12. (Toppdel)	1 vite lamiera Ø4.8x12 (terminale profilato)
8	1 screw M5x12 (base spar)	1 vis Chc M5x12 fixation profil bas	1 Schraube M5x12 (unteres Profil)	1 schroef M5x12 (basisprofiel)	1 tornillo M5x12 (perfil bajo)	1 insex M5x12 (Bottenprofil)	1 vite a brugola M5x12 (profilato basso)
9	14 screws M5x8 (spar connections)	14 vis TF M5x8 liaison profils	14 Schraube M5x8 (Verbindung der Profile)	14 bouten M5x8 (koppelstukken)	14 Tornillos M5x8 (unión perfiles)	14 insex M5x8 (profilkopplingarna)	14 vite M5x8 (collegamento profilati)
10	7 Coupling sleeves	7 pièces de jonction aluminium	7 Verbindungsstücke	7 koppelstukken	7 piezas de uniones	7 Skarvstycken	7 Pezzi di giunzione
11	7 PVC liners	7 profils PVC	7 PVC-Profile	7 PVC binnenprofielen	7 Perfiles PVC	7 Innerprofil i PVC - plastprofil	7 Profilati PVC
12	1 base spar	1 profil aluminium bas	1 unteres Profil	1 basisprofiel	1 perfil bajo	1 Bottenprofil	1 profilato basso
13	6 Intermediate spars	6 profils aluminium intermédiaires	6 Zwischenprofile	6 standaardprofielen	6 Perfiles intermedios	6 Standard profiler	6 Profilati intermedi
14	1 screw + nut M14x40	1 vis + écrou M14x40	1 Schraube M14x40	1 bunt M14x40	1 tornillo M14x40	1 insex M14x40	1 Vite M14x40

ASSEMBLY INSTRUCTIONS

FOR S-SERIES

406-S 609-S 811-S

INDEX

1/ TECHNICAL SPECIFICATIONS 406-S, 609-S, 811-S	3
2/ DESCRIPTION OF SPECIFIC PARTS FOR EACH MODEL	
2.1 - 406-S	4
2.2 - 609-S	5
2.3 - 811-S	6
3/ TOOLS NEEDED	7
4/ FLAT ASSEMBLY (forestay dismantled)	7
4.1 - Dismantling the forestay	8
4.2 - Assembly of the jib reefing system	9
4.3 - Assembling the last spar	9
4.4 - Assembling the top end stop	10
5/ IN SITU ASSEMBLY (directly onto the boat)	10
5.1 - Measuring the length of the forestay	10
5.2 - Cutting the last spar	11
5.3 - Assembling the top end stop	11
5.4 - Assembling the spars	11
5.5 - Assembling the base spar	12
5.6 - Cutting the PVC liner	12
5.7 - Assembling the boltrope prefeeder	12
5.8 - Assembling the drum unit	13
5.9 - Adjusting the reefing line feeders	13
6/ RECOMMENDATIONS	14
7/ OPTIONAL EXTRAS	15
8/ SPARE PARTS	
8.1 - 406-S	72
8.2 - 609-S	73
8.3 - 811-S	74



3/ TOOLS NEEDED

Tools needed :

- Hammer
- Pliers
- Comfortable bosun's chair (Plastimo).
- Allen key (4)
- Electric or hand drill
- 1 Ø4 mm drill
- Hacksaw
- Tape measure
- Screwdriver
- Silicone filler.

4/ FLAT ASSEMBLY

- This method consists of fully dismantling the forestay and assembling the jib reefing system while the forestay is lying flat.
- We recommend this method as it is faster.
- In certain cases the top part of the forestay cannot be dismantled, in this case::
do an in situ assembly (see page 10)
contact a professional who can install a universal joint on the upper part of the forestay.

4.1 - Dismantling the forestay

4.1.1 - Lower part

- Slacken the backstay
- Secure the mast forward with 1 or 2 halyards
- Tighten the halyards to relieve the strain on the forestay
- Dismantle the lower part of the forestay (this usually consists of removing a removing a rigging screw pin, or a screw and a nut).

Note : it is important to measure the distance between the forestay eye and the hole of the forward mounting plate in order to find the correct adjustments again.

For a turnbuckle assembly, measure the distance between the mounting plate and the blocking nut of the turnbuckle.

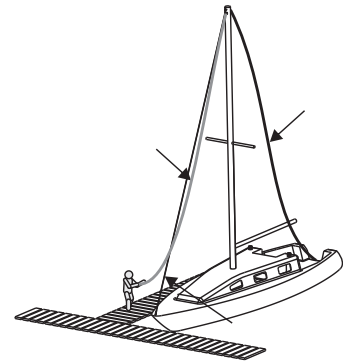

4.1.2 - Upper part

- Send a person to the masthead (equipped with hammer and pliers)
- Dismount the upper part of the forestay
- Bring the person and the forestay down from the masthead

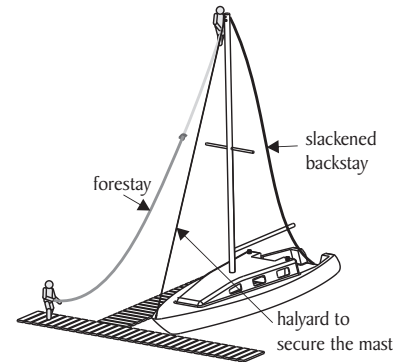

4.2 - ASSEMBLING THE JIB REEFING SYSTEM

- Lay the forestay flat



- Place the parts to be assembled alongside the forestay

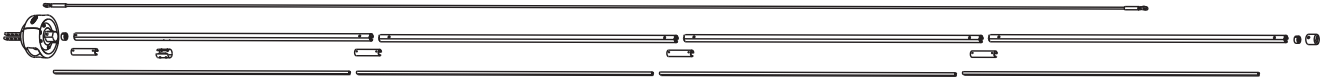

- Assemble the drum unit on the forestay and put the rigging screw pin or screw and nut in place (select the chainplate hole that corresponds to the initial forestay adjustment).

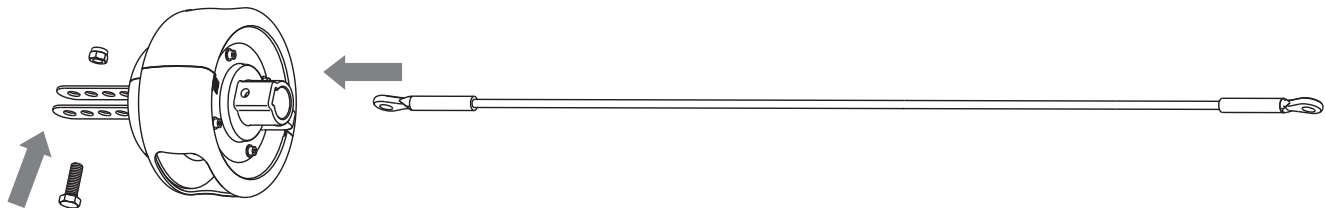

- Slide a bearing into the drum

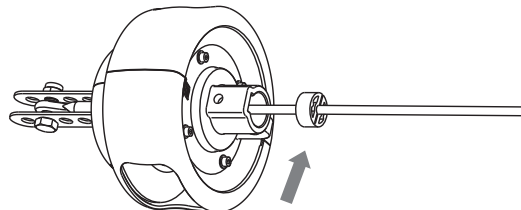

- Insert a coupling sleeve into the base spar (ensure that the hole in the coupling sleeve is in line with the pre-drilled hole of the base spar)

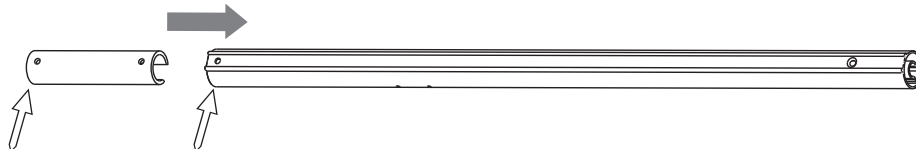

- Slide the base spar into the drum unit until the two holes are in line, insert the M5x12 screw (after putting some silicone filler in the hole in order to reduce the stainless steel / aluminium electrolytic couple) and tighten.

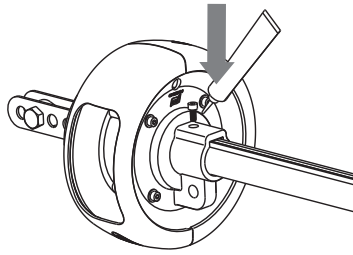

- Install the boltrope prefeeder; ensure it is the right way up, see diagram below.

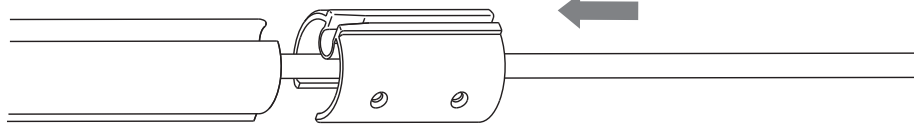

- Secure with the 4 screws $\varnothing 3.9 \times 9.5$

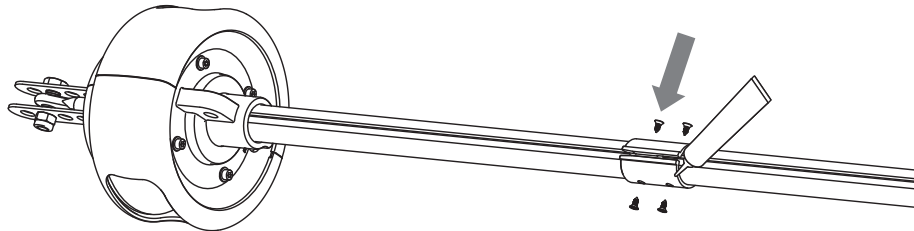

- Insert an aluminium coupling sleeve, put some silicone filler into the hole and position a MSx8 screw (do not tighten or it will be difficult to put the second screw in place).
- Put a second spar into position, put some silicone filler in the hole and position the screw (once the two screws are in position they may both be tightened). Wipe off any excess filler with a cloth.
- Insert PVC liners as you go along (ensure they are flush against the prefeeder)
- Repeat the process until only one spar is left

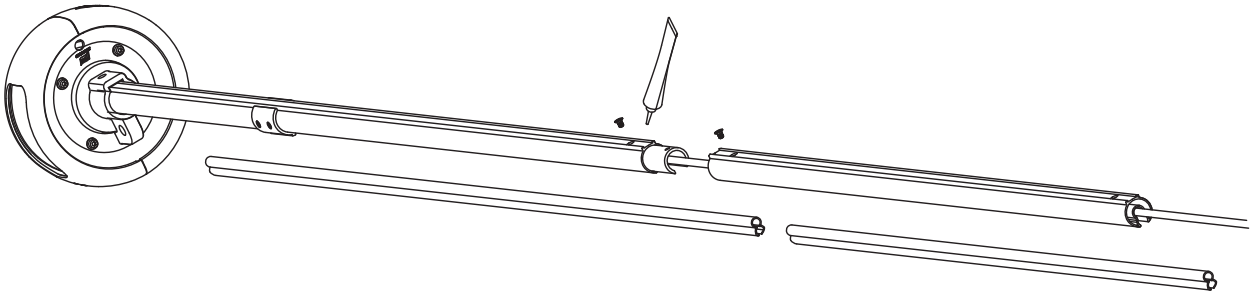

4.3 Cutting the last spar

- Position the last spar so that it lies flush against the previous spar but do not install it
- Measure a distance of 5 cm back from the sleeve of the forestay
- Mark and cut the spar with a hacksaw
- Put a coupling sleeve into position
- Insert the spar, then insert and tighten the screw

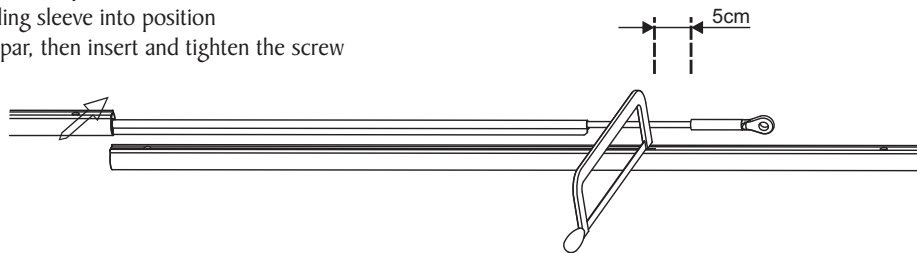

- Position the last PVC liner
- Mark the liner level with the end of the aluminium spar
- Cut and insert the PVC liner

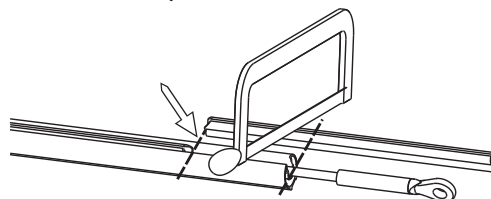

4.4 Installing the top end stop

- Slot the second bearing into the top end stop

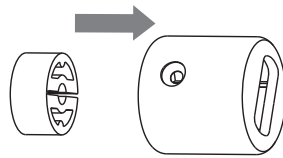

- Slide the top end stop over the aluminium spar
- Drill a hole (with a $\text{\O}4$ mm drill). IMPORTANT: refer to diagram for the positioning of the top end stop

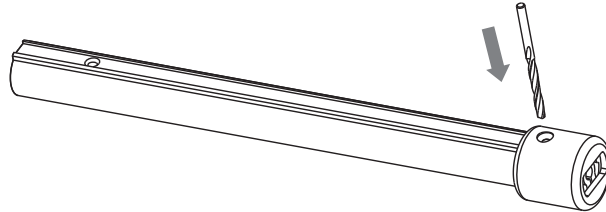

- Before putting the screw into position, do not forget to slide the halyard swivel into place (ensure that the conical end of the halyard swivel faces downwards)

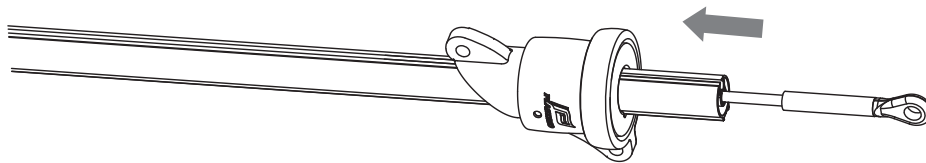

- Put the top end stop back into position
- Put some silicone filler into the hole
- Insert and tighten screw $\text{\O}4.8 \times 12.7$

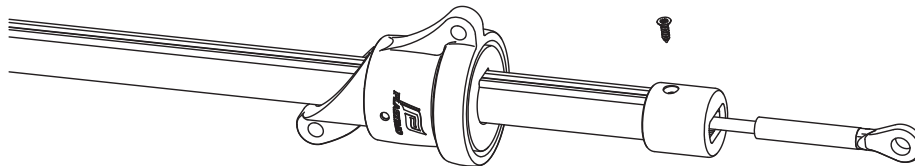

- Your jib reefing system is now assembled and can be put into position (hoist it up to the masthead with a halyard)



5/ IN SITU ASSEMBLY

- this method of assembly may be carried out by one person
- it is not necessary to dismantle anything at the masthead

5.1 - MEASURING THE LENGTH OF THE FORESTAY

In order for this jib reefing system to be perfectly adapted to your boat the length « X » needs to be known.

- Slide a small shackle around the forestay
- Ensure that it lies flush against the sleeve
- Slacken the backstay
- Secure the mast with a halyard
- Dismount the lower part of the forestay
- Assemble the drum unit
- Reassemble the lower part of the forestay
- Undo the halyard and tighten the backstay
- Attach a halyard to the shackle
- Attach a length of rope (or a tape measure) to the shackle
- Hoist the shackle until it touches the top sleeve of the forestay
- Mark the piece of rope level with the top of the drum unit
- Lower the shackle

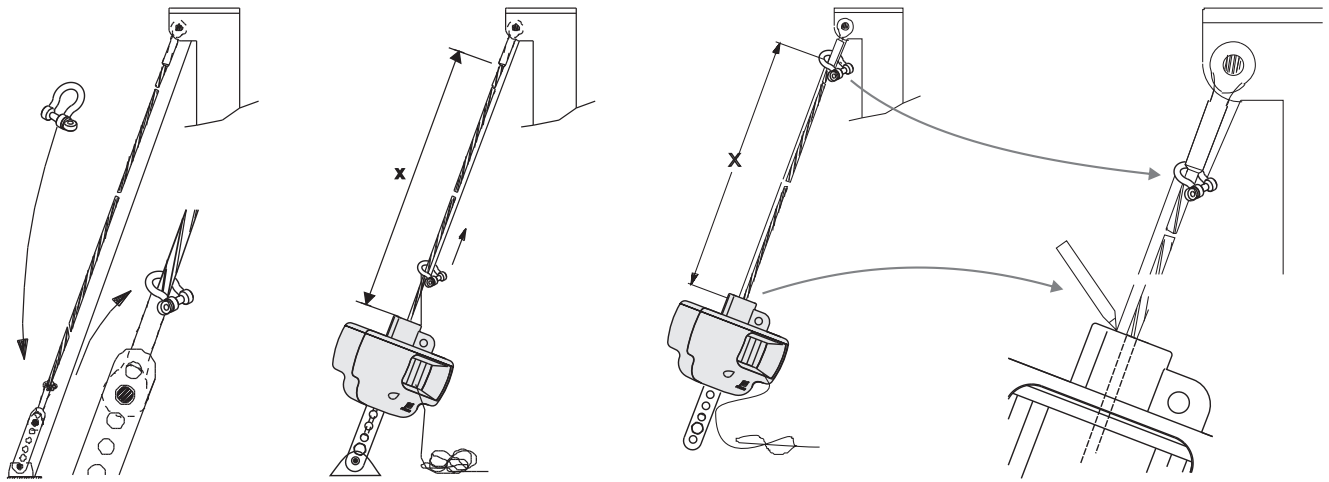

5.2 - CUTTING THE LAST SPAR

- Stretch out flat the piece of rope used to measure the length of the forestay
- Lay the aluminium spars parallel to the piece of rope (take note of base spar, see page 7)
- Mark the spar level with the mark on the piece of rope
- Cut the spar 3 cm (safety margin) below the mark

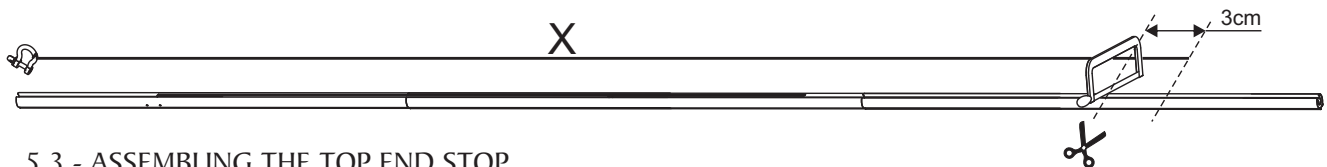

GB

5.3 - ASSEMBLING THE TOP END STOP

- The top end stop should be assembled on the aluminium spar that has just been cut.
 - a) The second bearing is slotted into the top end stop
 - b) Slide the top end stop fully over the end of the spar (IMPORTANT: refer to diagram below for positioning of the hole in the top end stop)
 - c) Drill a hole using a $\text{Ø}4$ mm drill

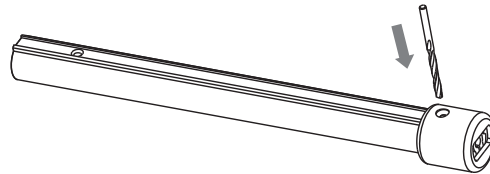
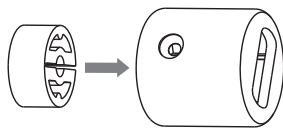

5.4 - ASSEMBLING THE SPARS

- Dismount the forestay from the stemhead fitting
- Install the following on the forestay :
 - Top end stop
 - Bearing
 - The spar that you have cut and drilled
 - 1 screw $\text{Ø}4.8 \times 12.7$
 - PVC liner
 - Halyard swivel (IMPORTANT: see drawing below for position of halyard swivel)

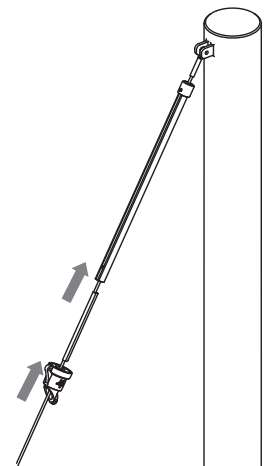
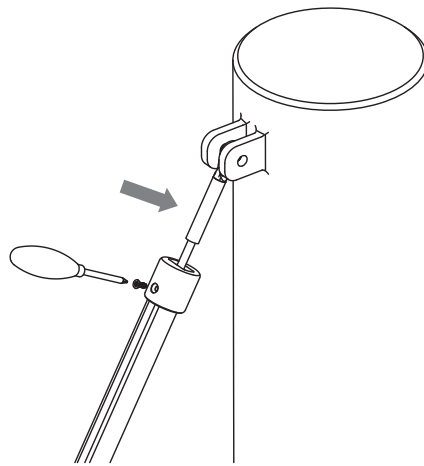
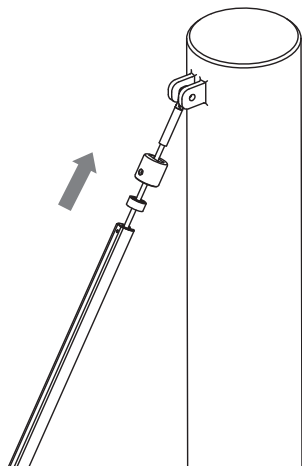

- Refasten the forestay
- Attach a halyard to the halyard swivel in order to support the spars as they are assembled
- Insert a coupling sleeve
- Put some silicone filler into the holes before tightening the screws (in order to reduce the electrolytic couple between the stainless steel screw and the aluminium)
- Insert an M5 x 8 screw
- Wipe away any excess silicone with a cloth
- Slide another aluminium spar into position
- Insert a PVC liner (IMPORTANT: keep the base spar to one side; you will be assembling it last)
- Repeat the process as many times as necessary

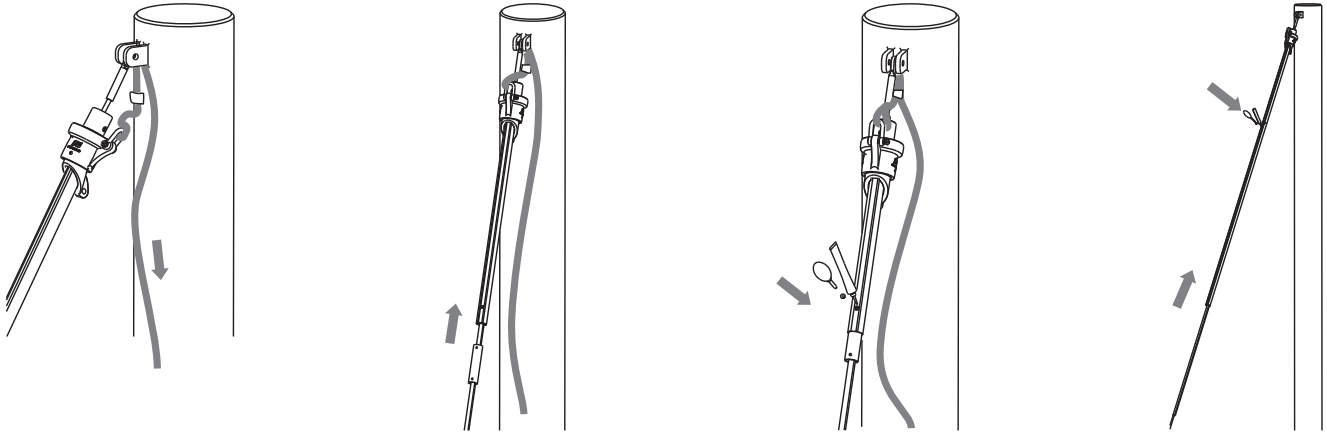

5.5 - ASSEMBLING THE BASE SPAR

- IMPORTANT: ensure the base spar is facing the right way (see diagram below)

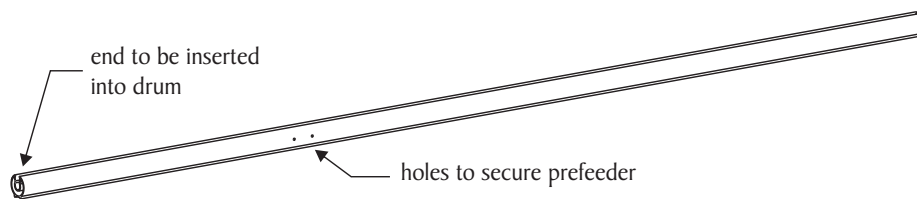

5.6 - CUTTING THE PVC LINER

- Slide the prefeeder into position from the bottom of the spar until it is in line with the holes in the spar (IMPORTANT: ensure that the prefeeder is the right way up)
- Insert a $\text{Ø}3.9 \times 9.5$ screw
- Position a PVC liner, mark and cut to required length
- Remove the prefeeder and install the cut PVC liner

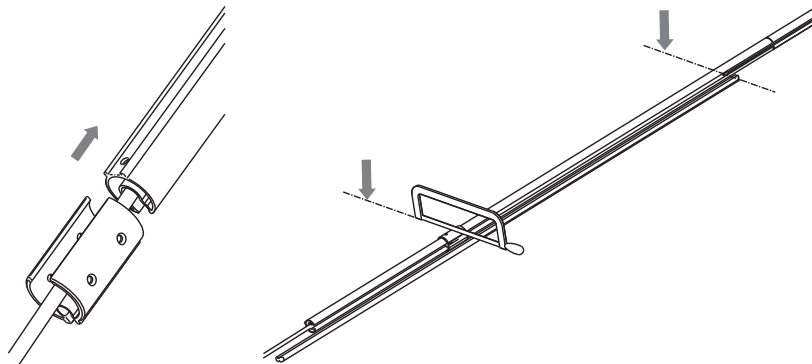

5.7 - INSTALLING THE BOLTROPE PREFEEDER

- Put the prefeeder back into position
- Put some silicone filler in the holes
- Insert and tighten the 4 $\text{Ø}3.9 \times 9.5$ screws
- Wipe away any excess filler with a cloth

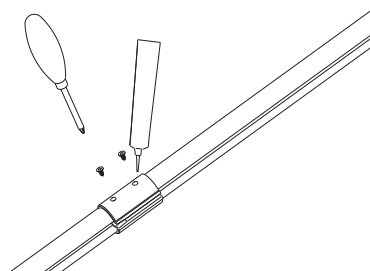

5.8 - ASSEMBLING THE DRUM UNIT

- Detach the forestay from its mounting plate on the boat
- Position the sleeve or turnbuckle* on the drum (*depending on model)
- Slide a bearing into the drum
- Insert a coupling sleeve into the base spar (ensure that the hole in the coupling sleeve is in line with the pre-drilled hole of the base spar)
- Insert the base spar into the drum unit
- Put some silicone filler in the pre-drilled hole
- Insert the M5x12 screw
- Attach the jib reefing system to the forward mounting plate
- Lower the halyard swivel
- Tighten the backstay

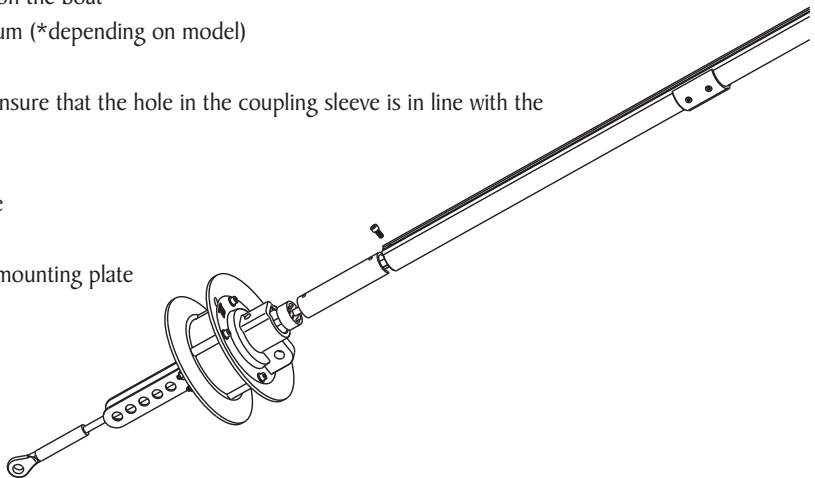

5.9 - ADJUSTING THE REEFING LINE FEEDERS

5.9.1 - 406-S model

- The reefing line feeder on the 406-S model is assembled either on the right or left hand side of the drum unit, depending on which direction you prefer to reef.
- To fasten the reefing line feeder, use the two M4x12 nuts and bolts

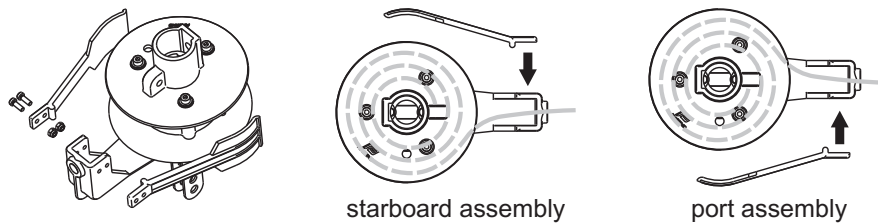

- The angle is adjusted by loosening the two screws that hold the chainplate.

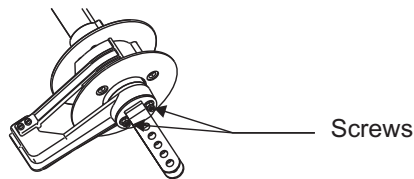

5.9.2 - 609-S & 811-S models

- The angle of reefing line feeders on 609-S & 811-S models is adjusted by loosening the two nuts and bolts (see diagram below)

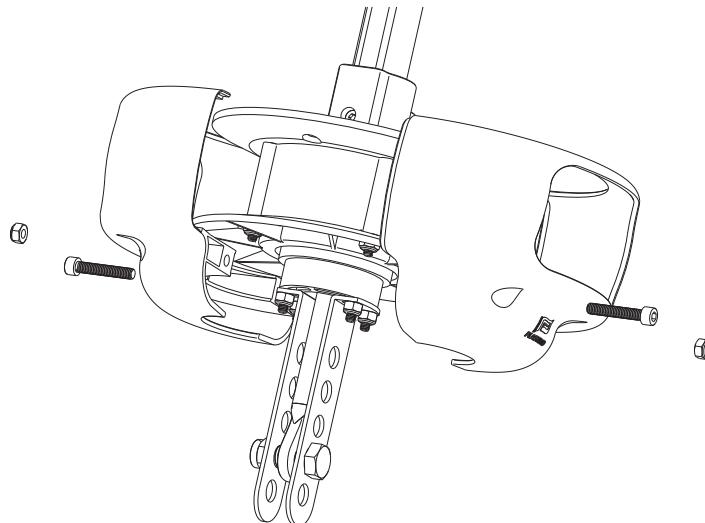

6/ Recommendations

Reefing line feeders

The angle of all the reefing line feeders may be adjusted.

IMPORTANT: they should be positioned in a way that best suits the direction of pull on the line

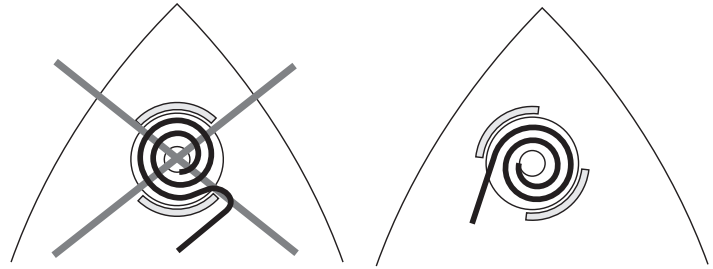

Reefing line

The reefing line is wound around the drum. Only use pre-stretched rope in order to eliminate any elasticity

Refer to diagram below for the position of the reefing line as it comes out of the drum

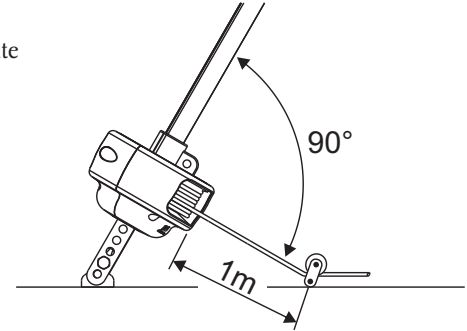

Reefing direction of the genoa

The genoa should be reefed in the same direction as the strands turn on the forestay.

When you are not sailing

Slacken the backstay in order to reduce undue strain on mechanical parts

About the drum

When your genoa is fully reefed and in order to avoid direct strain on mechanical parts and on the knot of the reefing line, there should be a minimum length of one halyard turn on the drum.

Halyard/forestay angle

This angle should never be more than 20-25° as this makes it impossible to tauten and reef the sail.

What is more, this undue strain on the forestay could cause it to unravel and even dismast the boat.

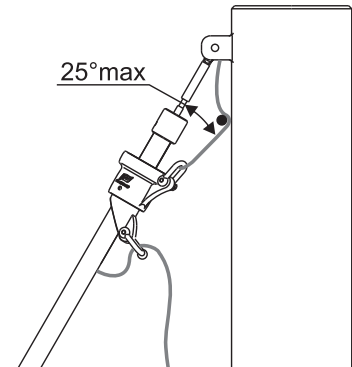

When sailing

Ensure that the forestay is always taut. Not only will this make reefing easier but will avoid any danger of the forestay unravelling. (We recommend putting a universal joint at the masthead)

Hauling on the genoa

The reefing line should never be used to haul on the sail.

Unfurling the genoa

When unfurling the genoa, ensure that it does not unfurl too quickly by winding the reefing line once round a winch and feeding it out slowly in one hand and the genoa sheet in the other.

Maintenance

Rinse the drum unit and the halyard swivel once a year with fresh water (no dismantling required).

No other special maintenance is needed.

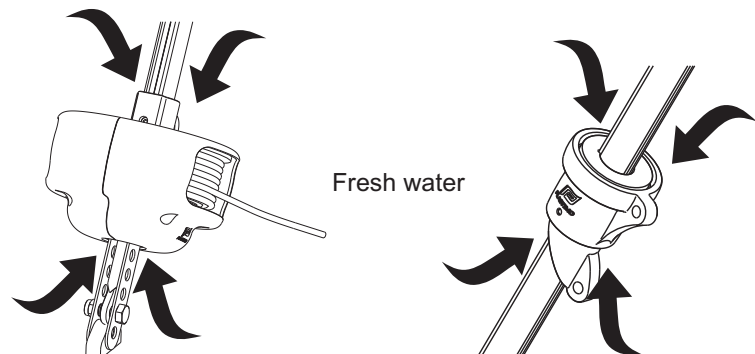

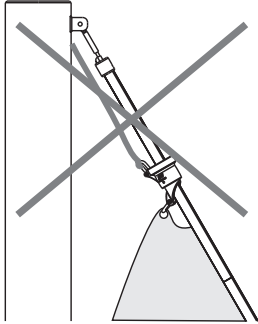
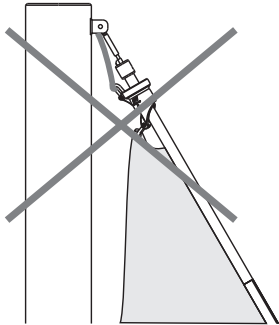
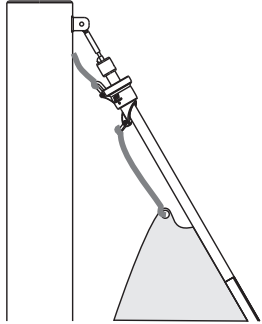
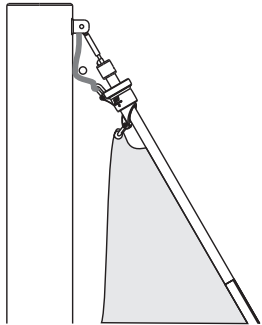
PROBLEM ENCOUNTERED	CAUSES	SOLUTIONS
Halyard turns with the halyard swivel	<ul style="list-style-type: none"> - Forestay not taut enough - Genoa halyard too slack - Genoa too short, halyard swivel too low  <ul style="list-style-type: none"> - Genoa halyard too close to the forestay 	<ul style="list-style-type: none"> - tighten the backstay - tauten the genoa halyard - Use a strop  <ul style="list-style-type: none"> - Fasten a halyard feeder to the mast or a diverter to the forestay 
The halyard tends to wrap itself around the spar when the genoa is hoisted	<ul style="list-style-type: none"> - Halyard is worn and thus twists in the direction of the rope strands 	<ul style="list-style-type: none"> - Change the halyard
Reefing line fouls	<ul style="list-style-type: none"> - Wrong angle on reefing line. - First sheave too far from drum unit. - Genoa unfurled too quickly 	<ul style="list-style-type: none"> - Change position of first sheave - Slow down the unfurling of the genoa by winding the reefing line once round a winch.
Genoa difficult to hoist	<ul style="list-style-type: none"> - Poor output from a sheave. - Halyard jammed - Luffrope too large 	<ul style="list-style-type: none"> - Try with a different halyard - Change luffrope

GB

7/ OPTIONAL EXTRAS

7.1 - HALYARD DIVERTERS

When the genoa is furled or unfurled, if the angle between the halyard and the forestay is too tight, the halyard risks being twisted round as the halyard swivel turns.

2 options are available to solve this problem:

7.1.1 : Halyard diverter wheel

To install the diverter wheel, it is necessary to dismantle the forestay

Ref : 25720

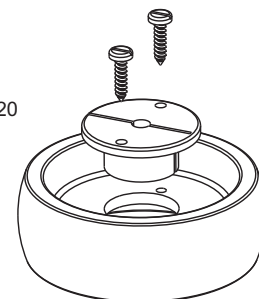

7.1.2 : Halyard feeder

To install the halyard feeder, it is not necessary to dismantle the forestay

2 sizes are available:

- ref 25677 : 609 et 811 models
- ref 26140 : 406 model

Ref : 25677

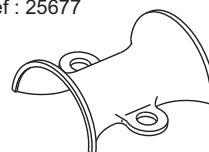

Ref : 26140

